

Operating Instruction

Original language: german

Product group: Spray gun

Product code: 203500500



ST-3500

Vers. February 19

Technical data

Maximum permissible pressure	350.0 bar / 35.00 MPa
Minimum pressure	0.0 MPa
Maximum flow rate	200.0 l/min
Permanent water temperature	90°C
Short term water temperature	max. 150°C
Ambient temperature	up to max. 60°C
Nozzle size	min. 020
Inlet connector	G1/2 fm
Outlet connector	G1/2 fm
Weight	1.229 kg
Dimensions (W / H / D)	226 x 243 x 39
Max. size of solids	50µm

Abbreviations and symbols	
fm; m	female thread; male thread
BSP	Whithworth pipe thread acc.to DIN ISO 228; ident. BSP = British Standart Pipe
NPT	National Pipe Thread
kg	kilogramme

	The spray gun is designed for a steady use up to 90°C. For short term applications 150 °C are also admissible. In any case the operator has to wear protective clothing such as gloves, safety shoes and glasses. The local safety regulations currently in force should always be observed.
	To reduce the risk of injury read operating instructions carefully before using! Keep the Operating Instructions in a safe place for future use or for the next user! Know how to stop the product and bleed pressures quickly. Be thoroughly familiar with the controls! Do not operate the product when fatigued or under the influence of alcohol or drugs! These Operating Instructions were prepared with great care. However SUTTNER GmbH cannot be held responsible for any possible errors in the Operating Instructions or for any consequences arising thereof!

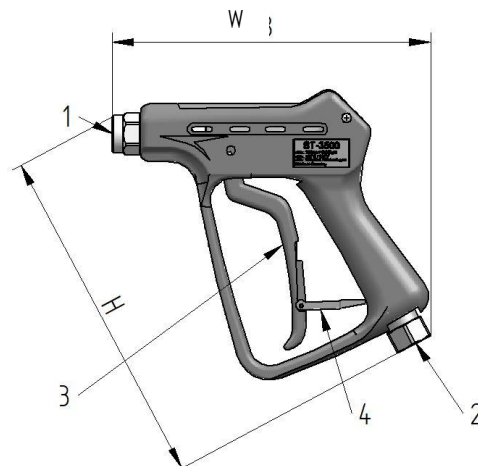

- 1 Outlet
- 2 Inlet
- 3 Trigger lever
- 4 Safety latch

Description

Spray gun

The ST-3500 is designed to be used for professional high-pressure cleaning (cold/hot water). The spray gun housing is made of impact-resistant plastic. The valve housing and connectors are made of anti-corrosion, high-quality metal. The trigger lever is equipped with a safety latch.

Intendet use

The spray gun is designed for dispensing pressurised fluids from high-pressure washers. All safety regulations and rules for high-pressure washers apply, e.g. DIN EN 60335-79-2 and DIN EN 1829-1. The spray gun must only be used with Group II fluids as per 2014/68/EU. This can include for instance water and commercially available cleaning or disinfection agents. For further details, please refer to Guideline 67/548/EEC.



Dispensing flammable, explosive, caustic or toxic substances is forbidden!

The spray gun must not be used with abrasive substances.

The spray gun must only be used in a technically perfect condition, unmodified in any way, for the purpose intended, in the awareness of safety requirements and potential hazards in compliance with these Operating Instructions. Only qualified operators in handling high-pressure washers may use the spray gun.

To avoid damaging the spray gun install a fine filter with a recommended mesh size of 50 microns into the water inlet to the high-pressure washer.

Please also comply with the operating instructions for equipment and accessories connected to the spray gun and with the applicable regulations for cleaning agents.

Normative references

- The product is classed as a pressure-maintaining component within the terms of Pressure Equipment Directive 2014/68/EU. Due to the operating parameters, it comes under the scope of Article 4 / Paragraph 3 of this guideline ("good engineering practice") and therefore no Declaration of Conformity and CE marking are allowed!
- The product must not be installed in equipment complying with the Pressure Equipment Directive 2014/68/EU.
- The product is a standard part within the terms of Machinery Directive 2006/42/EC!

Symbols and their meanings



Hazard!

If these instructions are not followed there is a danger of physical injury, danger to life and material damage!



Please comply with the Operating Instructions!

Incorrect operation can lead to severe injury. Read the Operating Instructions before using the equipment.



Wear safety gloves!



Wear protective goggles!



Risk of injury due to high pressure!

Risk of injection or severe injury to persons. Keep clear of nozzle. Do not direct discharge stream at persons.



Description of imminent hazard and failure to avoid hazard will result death



Description of hazard and possible resulting injuries or death.



Description of hazard that could result in minor or moderate injury.

For your safety

This Suttner product is state of the art and complies with generally recognised health and safety regulations. Due to the high pressures and temperatures nonetheless there is the danger of material damage and injury for users and other persons. Please comply with these Operating Instructions at all times and the relevant regulations for liquid jet washers.

For details regarding personal protective equipment, refer to the German accident prevention regulations "Personal protective equipment" (VBG101, at present Draft). Personal protective equipment includes for example overalls, head protection, easy-grip protective gloves and non-slip boots, metatarsal foot protection, respiratory protection, ear protection, eye or face protection.

Do not use the equipment if persons without protective clothing are within range.



DANGER Risk of injury due to spray medium!



- Before starting work, check the high-pressure system (spray equipment, hoses, screw connectors, etc.) for signs of leakage and damage.
- Stop operation immediately if any leakage or malfunctions occur.
- The spray gun trigger lever must not be blocked in the open position or prevented from closing in any other manner.
- Do not aim the spray nozzle at yourself or other living creatures, not even to clean clothing or footwear.
- Never place your hands in the way of the exiting high-pressure jet.
- If you are using cleaning agents, please read and observe the safety datasheets provided by the manufacturer of the cleaning agents.



CAUTION Risk of burning or scalding due to hot media!

Do not touch anything which is not insulated if you are working with consumables and additives where the temperature exceeds 45° C.



Wear protective gloves!



CAUTION Risk of falling due to exiting jet!

- Due to the high pressure of the exiting jet, you will experience a recoil force.
- Please ensure that you stand firmly
- Gun kicks back. Hold with both hands.
- Do not use the spray equipment when on slippery floors or ladders.
- Secure yourself on scaffolding or staging against falling.
- Remember that the use of angled lances produces torque forces. Make sure that the torque force does not exceed 20 Nm.



WARNING Risk of personal injury and material damage due to displaced particles!



During high-pressure cleaning, particles of dirt and other loose particles are displaced from the surface being cleaned. Due to the energy of the high-pressure jet, these particles are vastly accelerated and may lead to material damage and personal injury.



DANGER Risk of injury due to high pressure!



- Do not spray any objects containing harmful substances (e.g. asbestos) or which conduct electricity. The spray gun must not be used to clean fragile surfaces.
- Damage may occur when spraying fragile surfaces (e.g. car tires, painted surfaces). For fragile surfaces, do not use spot jet nozzles and keep a minimum distance. This minimum distance is dependent on the pressure and surface to be cleaned.

Assembly



Risk of injury!

Please note that high-pressure guns should only be used in conjunction with a lance which is at least 75cm long and which offers sufficient space for your other hand!

If the high-pressure system has been used with hot water, allow the equipment to cool down to below 45°C due to the risk of scalding or burning before starting assembly and maintenance work!

- Manual interference when the high-pressure generator is running can lead to serious accidents!
- Switch the high-pressure generator off before carrying out assembly work on the high-pressure system.
- Secure the high-pressure generator against being unintentionally switched on.
- Turn the water supply off.
- Ensure that system sections and lines to be opened are not under pressure.
- Seal the screw connectors in accordance with your intended use with an appropriate sealant such as Teflon sealing tape or a liquid sealant (see R+M Catalogue, Chapter 06, Adhesives and sealing materials).
- When assembling the lance and hose, secure the gun on the hexagon to prevent it turning and tighten the connectors to 25Nm.
- Connect the high-pressure hose from the high-pressure generator to the spray gun inlet.
- Assemble suitable accessories provided onto the output side.
- After maintenance and repair work, check that the safety latch works correctly.

UL requirements

- Spray gun can be used with cleaning machine type 3
- Check for correct length of lance, it should be 36in (914mm) for type 2 and 4 feet(1,22m) for type 3 machines
- Lance length have to be according UL 1776 §55

Modification

No modifications of any kind are to be made to the spray gun!

Recoil force

Due to the pressure of the exiting jet, the user of the high-pressure gun will experience recoil forces and torque.

In order to ensure the safety of the user, there are legal provisions for the permissible recoil forces and torque.

- Recoil forces up to max. 33lbf (150 N) are allowed without the need for additional shoulder support
- Recoil forces up to 56lbf (250 N) may occur if the high-pressure system is used with additional shoulder support
- Recoil forces which exceed 56lbf (250 N) are not allowed

The following diagrams and formulas give you a safe design for high-pressure operation:

Determining the recoil force

Use the following diagram to determine the height of the recoil.

1. Draw a horizontal line for the desired flow rate.
2. Draw a vertical line for the desired operating pressure.
3. Find the point of intersection of both lines
 - A If the point of intersection is below the 33lbf (150 N) limit, no further measures are needed
 - B If the point of intersection is above the 33lbf (150 N) limit, use a shoulder support
 - C If the point of intersection is above the 56lbf (250 N) limit, manual operation is no longer allowed

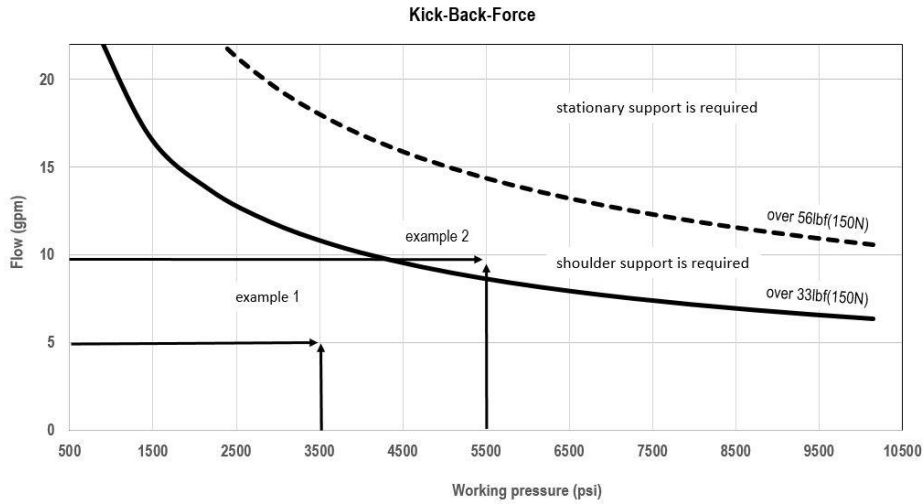

Example 1: For a flow rate of 4 gpm (15 l/min) and an operating pressure of 2900 psi (200 bar), the recoil force is less than 33lbf (150 N). No further measures are needed.

Example 2: For a flow rate of 10,5 gpm (40 l/min) and an operating pressure of 5000 psi (350 bar), the recoil force is greater than 33lbf (150 N). The spray equipment must also be equipped with a body support.

Determining the torque

Angled lances produce a torque. According to DIN EN 60335-2-79, a maximum torque of 14,8 lbf (20 Nm) is permitted on the handle of the spray gun. Make sure to adhere to the permissible torque for angled spray equipment.

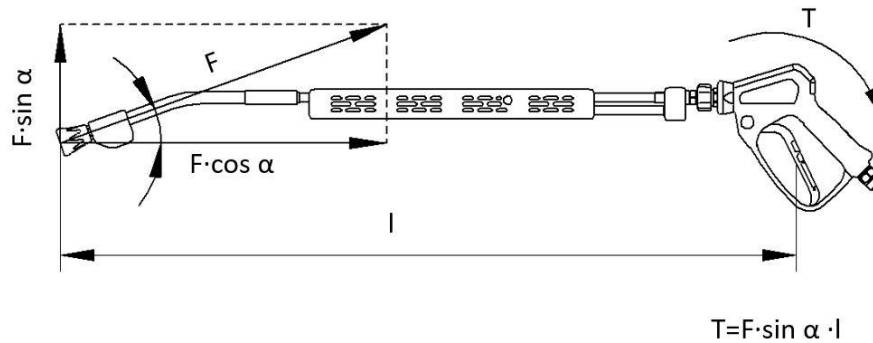

Example for calculating of torque: Where the recoil force is 22,5 lbf (100N), length is 3,3 ft (1m) and angle is 30°, the torque for example is already 36,8lbf (22,5 lbf x sin 30° x 3,3 ft) (50 Nm (100N x sin 30° x 1m)).

Calculating the discharge speed:

W- water discharge speed in ft/s (m/s)

p- operating pressure in psi (bar)

$$W = \sqrt{200 \times p}$$

Calculating the recoil force:

F- recoil force in lbf (N)

Q- flow rate in gpm (l/min)

$$F = \frac{W \times Q}{60}$$

Calculating the torque force:

T- torque in lbf (Nm)

l- length of lance in ft (m)

$$T = F \times \sin \alpha \times l$$

α- angle between nozzle and lance

Operation

Operate the spray gun only within the pressure, flow rate and temperature ranges indicated. Before starting work, check the values on the high-pressure generator and adjust these if necessary. After you have read the safety instructions, the spray gun is remarkably easy to use:

- Hold the spray unit firmly at the provided hand grip areas and make sure your footing is secure.
- To activate the spray gun, flip in the safety latch.
- Press the trigger lever to start spraying.
- Release the trigger lever to close the valve in the spray gun. The spray gun remains under pressure.
- To prevent the valve in the spray gun from inadvertently opening again, flip out the safety latch.
- Do not leave the spray gun unattended when the high-pressure generator is switched on.

Transportation and storage

Please ensure that the spray gun is cleaned and protected from contamination during transportation and storage. Protect the spray gun against frost. The effect of frost can damage the gun so badly that it no longer works perfectly.

Cleaning

- Clean the device prior to longer periods of inactivity. To clean the gun exterior, use a lint-free cleaning cloth and do not use any aggressive cleaning agents.
- Actuate the gun briefly to release any residual pressure. The high-pressure washer must be switched off.
- If you are using the gun with cleaning or disinfection agents, rinse the gun before and after use and prior to longer periods of inactivity (as from 1 hour). To do so, actuate the spray gun and rinse it thoroughly with clear water to clean the internal parts of the gun.

Maintenance

CAUTION Important safety instructions!

Assembly, maintenance and repair work may only be carried out by persons trained in maintenance and repair work on wet jet systems and high-pressure systems. Use only spare parts approved by Suttner GmbH. Only use components (hoses, connectors, etc.) approved for the respective pressure and temperature range.

- Every year, check that the spray gun is safe to use. Arrange to have any defects immediately rectified by an expert.
- Are the markings and inscriptions legible?
- Does the spray gun close automatically?
- Does the safety latch work?
- Does the spray gun show signs of mechanical damage?

After max. 1000 operating hours or a year or if hot water (exceeding 90°C) and chemicals are used after 500 operating hours or 6 months: Check valve parts (seal seat, O-rings, support rings, ball, piston rod, pressure piece) for damage and if necessary replace completely with a Suttner repair kit.

After max. 3000 operating hours or 3 years or if hot water (exceeding 90°C) and chemicals are used after 1500 operating hours or 18 months: Replace valve parts (seal seat, O-rings, support rings, ball, piston rod, pressure piece) completely with a Suttner repair kit.

Disposal



Please dispose of old equipment in an environmentally friendly manner.

Old equipment contains valuable recyclable materials which should be salvaged for recycling. Please therefore dispose of old equipment at suitable collection points.

